

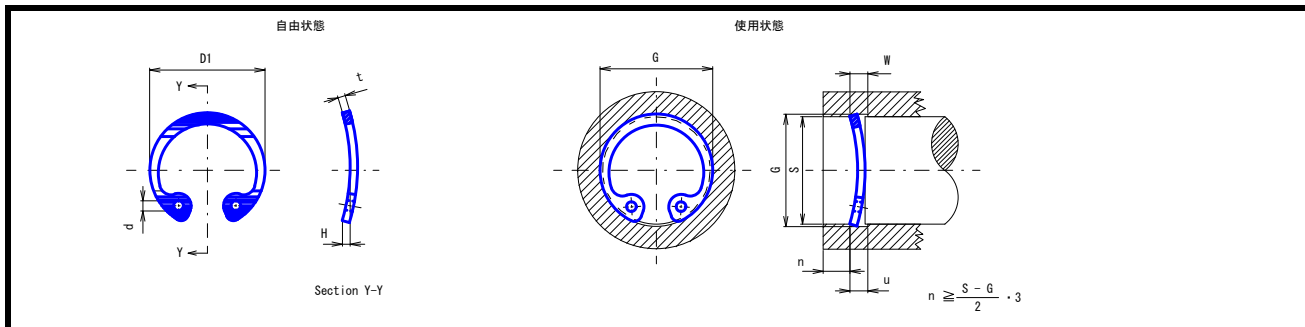

穴用湾曲BO型リング (IWT規格)



品名	穴径 S	リング寸法						溝寸法				単位 mm	
		内径		板厚		孔径 d	湾曲高さ H	溝径		溝巾		溝深 n	許容スラスト荷重 (リング)安全率4
		D1	公差	t	公差			G	公差	W	公差		
BO-6	6	6.5	+0.12	0.40	±0.03	0.8	0.38	6.4	±0.06	0.78	±0.07	13	189
BO-7	7	7.5	-0.05	0.40		0.8	0.38	7.4		0.78		10	220
BO-8	8	8.7	0.40	0.40		0.8	0.38	8.5		0.78		8	250
BO-9	9	9.7	0.40	0.40	±0.05	0.8	0.38	9.6	±0.07	0.78	-0	6	280
BO-10	10	10.8	0.65	0.65		1.0	0.38	10.6		1.03		22	500
BO-11	11	11.8	0.65	0.65		1.2	0.38	11.7		1.03		18	560
BO-12	12	12.6	0.65	0.90	±0.05	1.2	0.38	12.7	±0.07	1.03	-0	15	610
BO-13	13	13.9	0.90	0.90		1.2	0.50	13.6		1.40		52	920
BO-14	14	15.2	0.90	0.90		1.2	0.50	14.8		1.40		45	990
BO-15	15	16.2	0.90	0.90	±0.05	1.2	0.50	15.8	±0.07	1.40	-0	42	1,000
BO-16	16	17.3	0.90	0.90		1.6	0.50	16.9		1.40		38	1,100
BO-17	17	18.3	0.90	0.90		1.6	0.50	18.0		1.40		32	1,200
BO-18	18	19.5	0.90	0.90	±0.05	1.6	0.50	19.0	±0.07	1.40	-0	26	1,250
BO-19	19	20.5	0.90	0.90		1.6	0.50	20.0		1.40		20	1,300
BO-20	20	21.6	1.00	1.00		1.6	0.50	21.1		1.50		31	1,900
BO-21	21	22.7	1.00	1.00	±0.05	1.6	0.50	22.2	±0.07	1.50	-0	28	2,000
BO-22	22	23.7	1.00	1.00		1.6	0.50	23.2		1.50		25	2,100
BO-23	23	24.7	1.00	1.00		1.6	0.50	24.2		1.50		23	2,200
BO-24	24	25.7	1.00	1.00	±0.05	1.6	0.50	25.3	±0.07	1.50	-0	21	2,300
BO-26	26	28.2	1.00	1.00		1.6	0.50	27.4		1.50		19	2,500
BO-28	28	30.2	1.40	1.40		2.0	0.50	29.5		1.90		34	3,800
BO-30	30	32.4	1.40	1.40	±0.10	2.0	0.50	31.7	±0.10	1.90	-0	23	4,100
BO-32	32	34.5	1.40	1.40		2.0	0.50	33.8		1.90		20	4,400
BO-35	35	37.7	1.40	1.40		2.0	0.50	36.9		1.90		18	4,800
BO-37	37	39.9	1.40	1.40	±0.10	2.0	0.50	39.0	±0.10	1.90	-0	16	5,000

スナップリングの標準材質は、JIS G 3311 (SK-85M)です。その他は受注生産となります。