

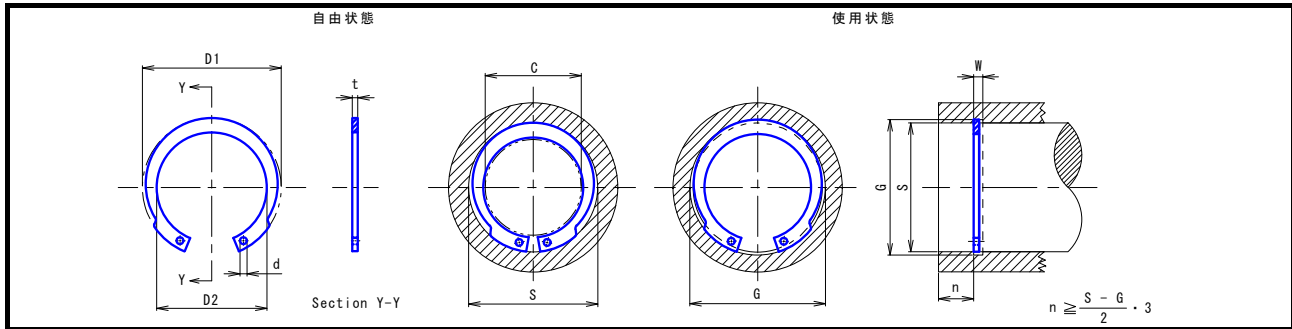

# 穴用OV型リング (IWT規格)



単位 mm

品名	穴径 S	リング寸法					溝寸法				挿入 直径 C	許容スラスト荷重 (リング)安全率4 SK85M kg	
		内径		内径	板厚	孔径	溝径		溝巾				
		D1	公差	D2	t	公差	d	G	公差	W			公差
OV-15	15	16.1	+0.15	12.6	1.00	±0.05	1.0	15.8	+0.10 -0	1.10	+0.08 -0	11.0	800
OV-16	16	17.3	-0.10	13.1	1.00		1.3	16.8		1.10		11.5	880
OV-17	17	18.3	+0.20	14.1	1.00		1.3	17.8		1.10		12.5	930
OV-18	18	19.5		1.00	1.3		19.0	1.10		13.3		990	
OV-19	19	20.5		1.00	1.3		20.0	1.10		14.3		1,000	
OV-20	20	21.5	-0.12	16.9	1.00		1.3	21.0	+0.15 -0	1.10	+0.08 -0	15.1	1,100
OV-21	21	22.5		1.00	1.3		22.0	1.10		16.0		1,150	
OV-22	22	23.5	±0.20	18.7	1.00		1.3	23.0	+0.20 -0	1.10	+0.08 -0	16.9	1,200
OV-24	24	25.9		1.20	1.5		25.2	1.30		18.1		1,500	
OV-25	25	26.9		1.20	1.5		26.2	1.30		19.1		1,600	
OV-26	26	27.9		1.20	1.5	27.2	1.30	19.7		1,700			
OV-27	27	29.1	±0.25	23.1	1.20	1.5	28.4	+0.25 -0	1.30	+0.10 -0	20.7	1,750	
OV-28	28	30.1		1.20	1.5	29.4	1.30		21.3		1,800		
OV-30	30	32.1		1.20	1.5	31.4	1.30		23.1		1,900		
OV-32	32	34.4		1.20	1.5	33.7	1.30		24.9		2,100		
OV-33	33	35.5		1.20	1.5	34.7	1.30		25.9		2,150		
OV-35	35	37.8		1.50	1.7	37.0	1.60		27.7		2,800		
OV-36	36	38.8	1.50	31.6	1.50	1.7	38.0	+0.25 -0	1.60	+0.10 -0	28.3	2,900	
OV-38	38	40.8		1.50	1.7	40.0	1.60		29.9		3,100		
OV-40	40	43.5	1.75	35.5	1.75	2.0	42.5	1.85	31.2	3,800			
OV-42	42	45.5	±0.38	37.1	1.75	2.0	44.5	1.85	1.85	+0.10 -0	32.8	4,000	
OV-45	45	48.5		1.75	2.0	47.5	1.85		35.4		4,300		
OV-47	47	50.5		1.75	2.0	49.5	1.85		37.0		4,500		
OV-48	48	51.5	±0.45	41.3	1.75	2.0	49.5	1.85	1.85	+0.12 -0	37.6	4,600	
OV-50	50	54.2		2.00	2.5	53.0	2.15		38.8		5,500		
OV-52	52	56.2		2.00	2.5	55.0	2.15		40.8		5,700		
OV-55	55	59.2		2.00	2.5	58.0	2.15		43.4		6,000		
OV-58	58	62.2	2.00	51.6	2.00	2.5	61.0	+0.30 -0	2.15	+0.12 -0	46.2	6,300	
OV-60	60	64.2		2.00	2.5	63.0	2.15		48.0		6,500		
OV-62	62	66.2	2.00	2.5	65.0	2.15	50.0	6,800					
OV-65	65	69.2	±0.54	58.2	2.50	2.5	68.0	2.65	2.65	+0.12 -0	52.5	8,900	
OV-67	67	71.5		2.50	2.5	70.0	2.65		54.1		9,200		
OV-68	68	72.5		2.50	2.5	71.0	2.65		54.9		9,300		
OV-72	72	76.5		2.50	2.5	75.0	2.65		58.5		9,900		
OV-80	80	85.5		2.50	2.5	83.5	2.65		65.6		11,000		
OV-85	85	90.5		3.00	77.5	3.00	3.0		88.5		3.15	70.0	14,000
OV-90	90	95.5	±0.54	81.9	3.00	3.0	93.5	+0.35 -0	3.15	+0.12 -0	74.4	14,500	
OV-95	95	100.5		3.00	86.1	3.00	3.0		98.5		3.15	78.6	15,500
OV-100	100	105.5		3.00	90.5	3.00	3.0		103.5		3.15	83.0	16,500

上記規格表に明示されている許容スラスト荷重は、各スナップリング(安全率=4)PR であり、実際の締結許容スラスト荷重は使用軸材質によりテストを行って下さい。